

Driver: _____

Date: _____

Tracks: _____

Events: _____

Conditions: _____

Rev:2

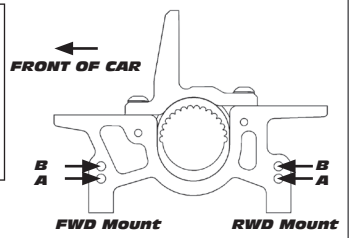
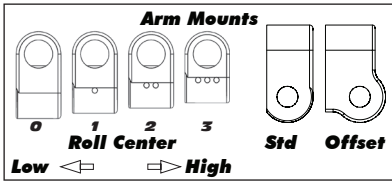
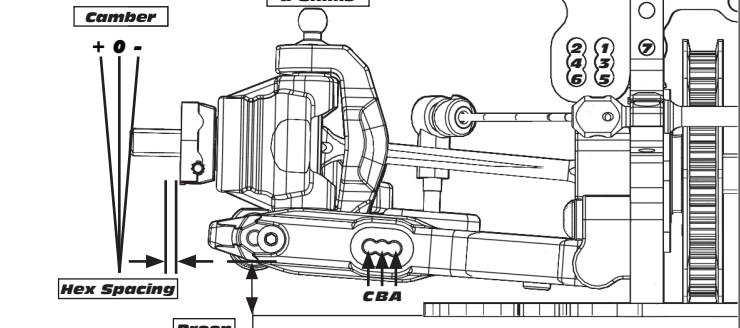
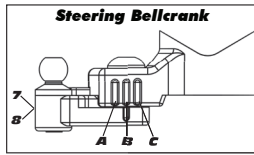
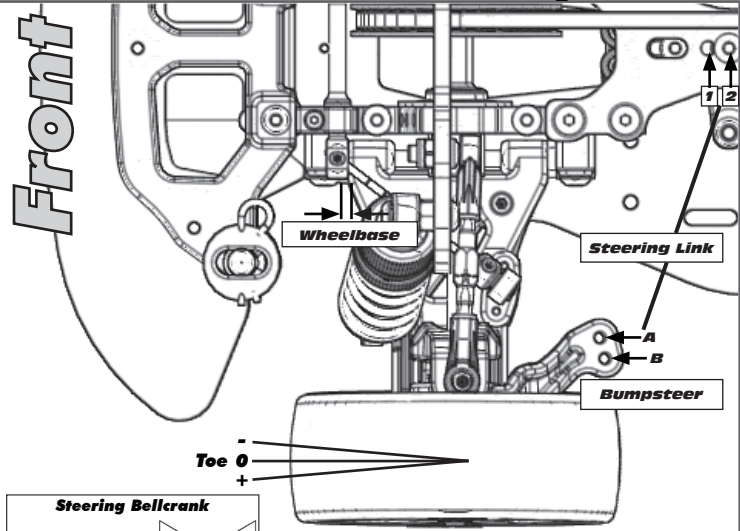

Transmitter	
Turning Circle:	
Steering Expo:	
Brake E.P.:	
Throttle Expo:	
Motor	Gearing
	/
Notes:	Notes:

Speed Control	
E.S.C. Type:	
E.S.C. Settings:	S.W. Ver.
Notes:	Notes:

Front	Alignment	Rear
	Ride Height	
	Camber	
	Caster	N/A
N/A	Rear Hub Toe	
	Toe (Total)	
	Hex Spacing	
	Wheelbase	
	Steering Bellcrank	N/A
	Steering Link	N/A
	Bumpsteer	N/A

Notes:

Suspension Geometry	
	Shock Position
	Camber Link Position
	Inner Ball & Shims
	Outer Ball & Shims
	FWD Arm Mount
	FWD Mount Shim
	RWD Arm Mount
	RWD Mount Shims
	Droop
	Anti-Roll Bar

Notes:

Shocks	
	Oil
	Piston
	Rebound
	Spring

Notes:

Differentials	
	Type
	Setting
	Cam Holder
	Belt Tension Number

Notes:

Tires	
	Type
	Tire Diameter
	Insert & Wheel
	Additive & Amount

Notes:

Chassis	
	Chassis
	Top Plate
Notes:	Notes:

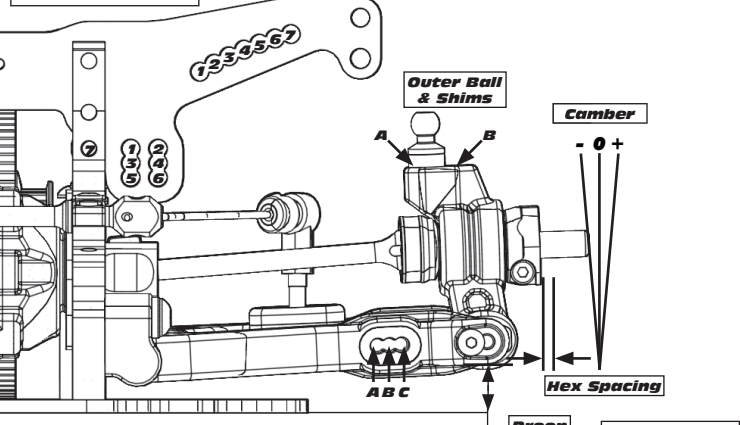
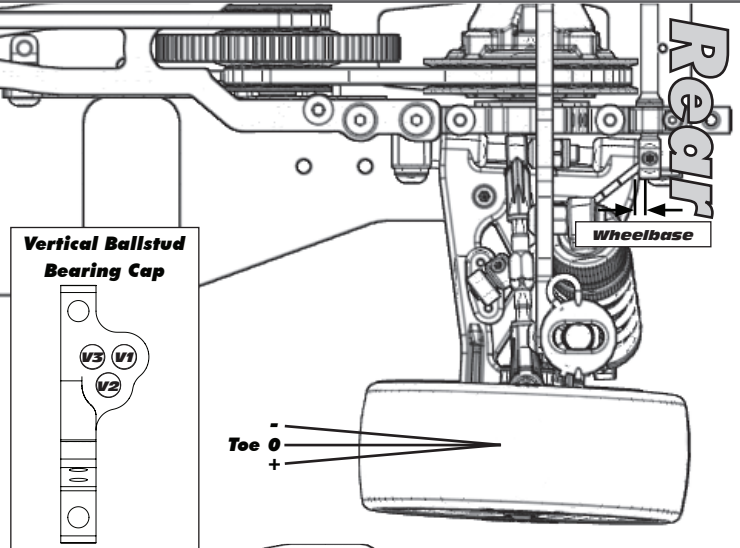

<p>FRONT OF CAR</p> <p>Labels: B, A, FWD Mount, RWD Mount</p> <p>Belt Tension Number</p> <p>Labels: 1, 16, 17, 32</p> <p>View from left side of car</p>	<p>Cam Holder</p> <p>Labels: A, B</p>
<p>Wheel Base Shims</p> <p>Labels: 1mm, 2mm</p>	<p>Arm Mount Shims</p> <p>Labels: 1°, 1.5°, 2°</p>
<p>Battery Placement</p> <p>Notes:</p>	<p>Body & Wing</p> <p>Notes:</p>